

APPROVALS : Tested and approved to EN54 Part 5 by the Loss Prevention Council, Germanischer Lloyd, ATEX

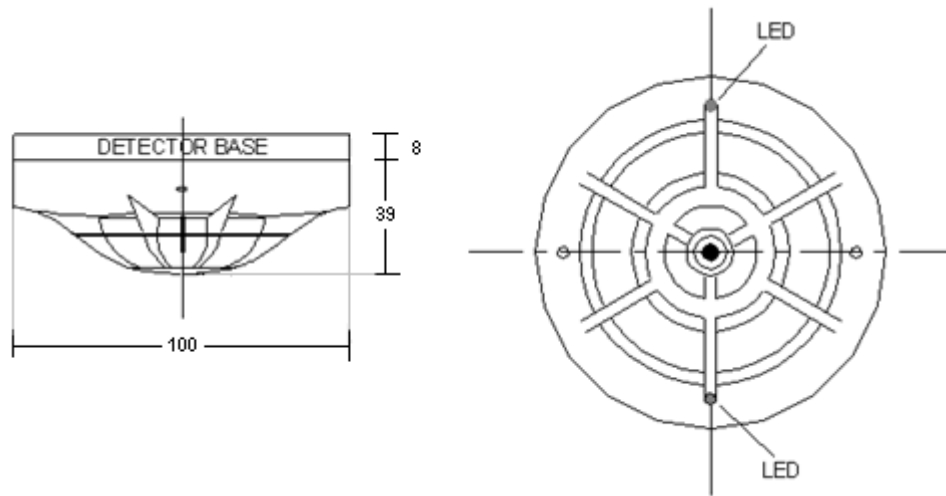

SPECIFICATION

Order Code	2302
Operating Voltage	15 – 30v DC, Nominally 24v DC
Quiescent Current	50uA at 24v DC
Alarm Current	50mA max at 24v DC
Operating Temperature	-10 ⁰ C to +55 ⁰ C
Material	ABS
Colour	Ivory White
Weight	97g
Dimensions	100 Diameter x 39 Depth (47 Depth with base)
Ingress Protection	IP63
Maximum Humidity	95% RH – non condensing (at 40 ⁰ C)
Base Fixing Centres	48 ~ 74