

2417 ADDRESSABLE TWO POSITION KEY SWITCH MANUAL CALL POINT***fi*APPLICATIONS**

The 2417 Addressable Two Position Key Switch Manual Call Point is suitable for indoor use on addressable type fire alarm systems. It provides a switching product solution for fire and security applications where the security of key operation is required such as a Ward in a Mental Hospital, or where plant or other mains operated equipment needs manual control.

**FEATURES**

- Easy to install
- Suitable for fire, security and other specialist applications
- Surface and flush mounting options
- Fully approved to BSEN54 Part11

OPERATION

The 2417 Addressable Two Position Key Switch MCP comprises of a main housing and escutcheon plate. The switching device is fitted to the plate, which simply snaps in to the main housing and is permanently located into place by fixing screws.

A fire alarm is initiated by the operation of a switch which requires the use of a dedicated key, usually held by staff members. When the key switch is operated, it closes a pair of contacts and activates an addressable input unit (Ref 2817). The system can be reset once the key is withdrawn by operating the system reset switch on the fire alarm control panel. The switches are supplied with flying leads and are normally used in conjunction with a back box fitted with terminals.

The Call point is primarily supplied in red, but other colours such as green, blue, white and yellow are available in special order. There are also numerous function marking options available to meet your specific requirements.

The key operated MCP is also available as a non-addressable version (Ref 2418) and a three position key switch (Firemans override) is available via special order.

APPROVALS: Fully approved to latest EN54-11 standard

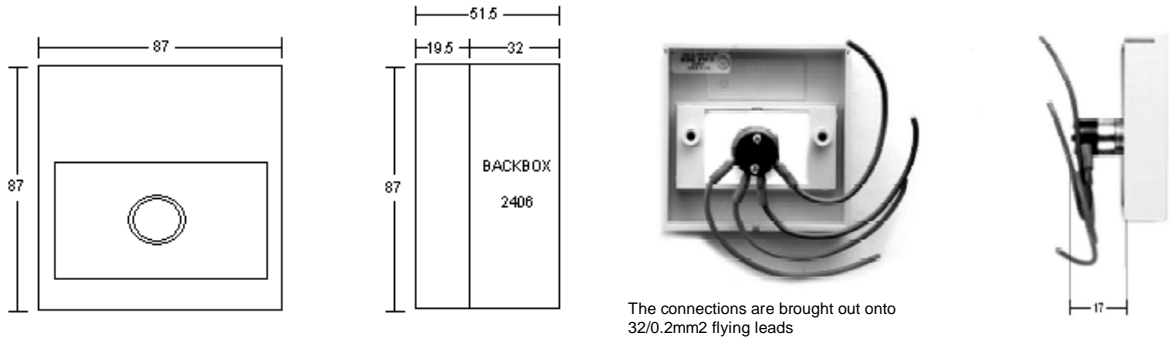

The connections are brought out onto 32/0.2mm² flying leads

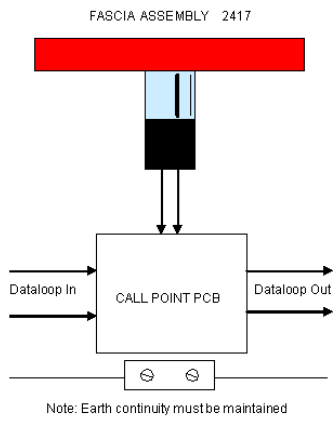

SPECIFICATION

Order Code	2417
Maximum Voltage	240VAC or 24 VDC
Operating Temperature	-30°C to +70°C
Material	ABS
Colour	Red (green, white, yellow, blue available on special order)
Weight	110g Flush 160g Surface
Dimensions	87 W x 87 H x 19.5 D (Recessed) 87 W x 87 H x 51.5 D (Surface)
Ingress Protection	IP24
Maximum Humidity	95% RH – Non Condensing (at 40°C)