

2616 RED SOLENOID WATERPROOF BELL**APPLICATIONS**

The 2616 Red Solenoid Waterproof Bell is a unique alarm bell designed for outdoor use in fire, security and other signalling system.

The improved aesthetics make the bell suitable for all applications including the most prestigious locations.

**FEATURES**

- High Sound Output
- Integrated electronic control circuitry
- Easy Installation
- IP55 (with weatherproof gasket)
- No back box required for surface wiring
- Low current consumption

OPERATION

The 2616 Red Solenoid Waterproof Bell utilises a combination of a miniature solenoid with an integrated control circuit allowing excellent sound coverage, minimum current consumption and increased reliability.

The 2616 Solenoid sounder is weatherproof rated to IP55, making it suitable for use in arduous environments.

APPROVALS : Fully approved to latest EN54-3 standard

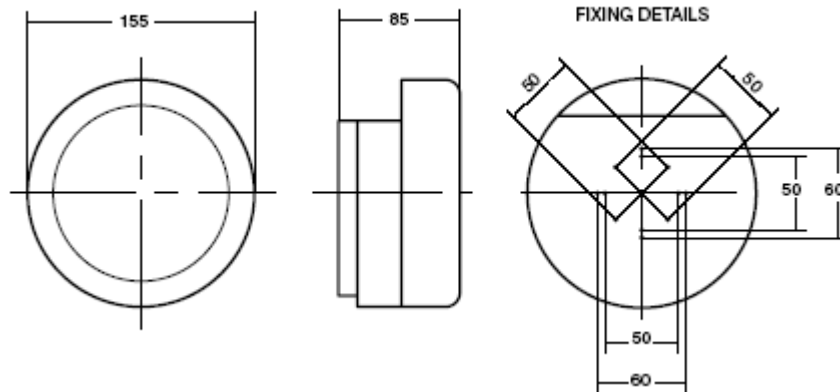

SPECIFICATION

Order Code	2616
Operating Voltage	18 - 30V DC,
Current Consumption	30mA at 24Vdc
Operating Temperature	-10°C to +55°C
Sound Output	Between 93dB – 95dB
Alarm Tones	1
Materials	Gong – Steel Base - Polycarbonate
Colour	Red
Weight	1.1kg
Dimensions	155 Diameter x 85 Depth
IP Rating	IP55