

2830 MAGNETIC DOOR RETAINER (24VOLT DC)**APPLICATIONS**

The 2830 Magnetic Door Release Unit is typically used in Elderly Persons Homes, Hospitals, Schools and other places where fire doors are in frequent use. Magnetic Door Release Units are designed for use with automatic fire alarm systems in buildings where fire doors are normally required to be kept open.

**FEATURES**

- Override Push Button Release Facility
- Holding Force 40Kg
- Bracket for Floor Mounting Available
- Low Current Consumption
- 240v AC Model Available
- Spring Ejector
- Dual Mounting position for Manual Release button

OPERATION

The 2830 Magnetic Door Retainer (24 Volt DC) unit consists of two parts – the doorplate, which is fitted to the fire door, and a solenoid unit, which is normally positioned on the adjacent wall. The solenoid is controlled by the fire alarm system so that it is continuously energised, thus magnetically attracting the doorplate and holding the door open. A Manual Release Button is fitted in the side of the solenoid unit. When the fire alarm system operates the 24v DC output is removed from the solenoid and the door is released. The door should be fitted with a self-closing mechanism.

A floor-mounting bracket (Ref 2832) is available for use if wall mounting of the solenoid unit is not convenient.

Magnetic Door Release Units are also available for 230v AC operation (Ref 2831). Transformer rectifier units are available for the 24v DC models where a local power supply is preferred. Separate single gang door release switches are also available for additional operational convenience (ref 2841).

APPROVALS: Suitable for control of fire doors in accordance with BS5839: Pt 1:2002.

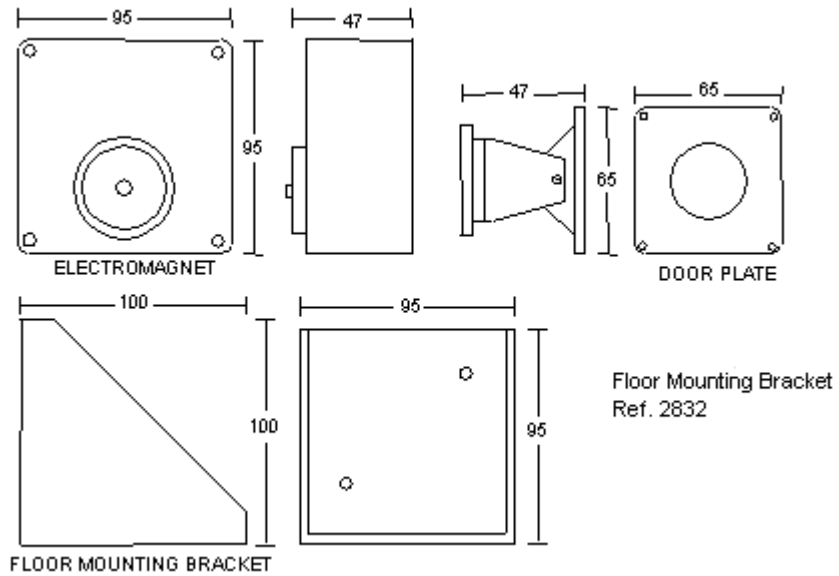

SPECIFICATION

Order Code	2830
Input Voltage	24v DC
Current Consumption	75mA
Operating Temperature	-10°C to +40°C
Material	
Electromagnet Unit	Di-cast Aluminium back box with thermoplastic cover
Floor Mounting Bracket	1.5mm Sheet Steel, White Powder Gloss Finish
Colour	
Electromagnetic Unit	White back box with Black Cover
Door Plate	Black with Polished Steel Plate
Floor Mounting Bracket	White
Weight	
Electromagnetic Unit	0.84 Kg
Floor Mounting Bracket	0.44 Kg
Dimensions	
Electromagnetic Unit	95 H x 95 W x 47 D
Door Plate	65 H x 65 W x 47 D
Ingress Protection	IP42